



VISO LIGHTING

ALO

INSTALLATION MANUAL

SM – LED 350mA 110V - 240V
1 x 1W LED (Integral)



IMPORTANT

Always shut off power before cleaning and maintenance.

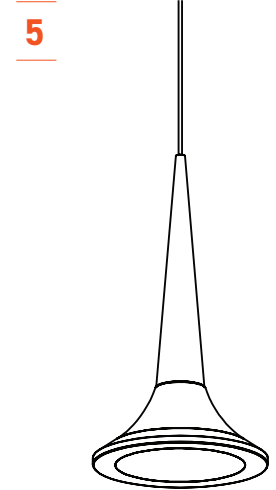
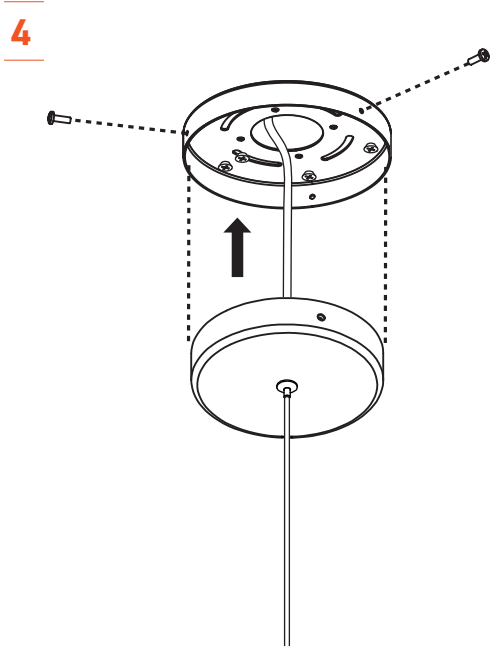
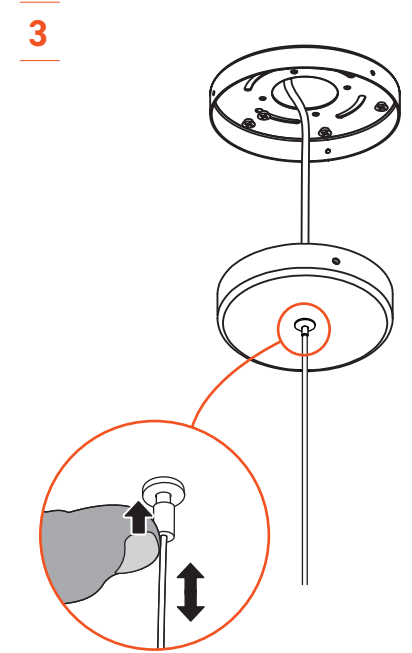
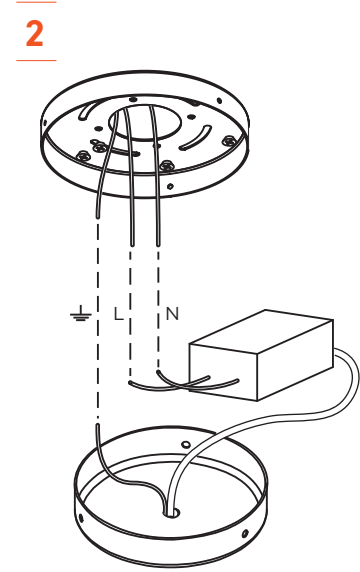
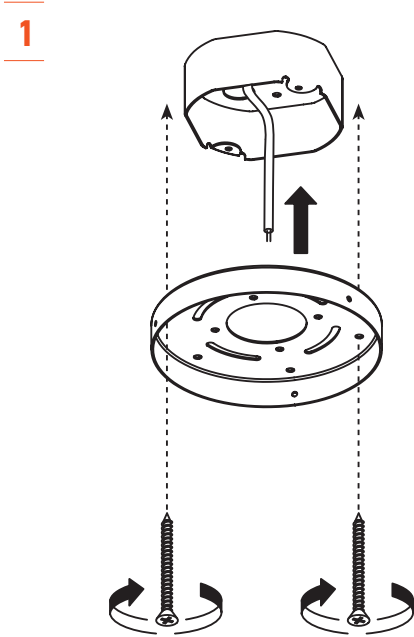

All products are manufactured to meet or exceed North American standards C22.2-250, UL 1598, C22.2-12, C22.2.9, UL 153.

All preparation for installation of fixture is to be provided by the end user.

The description and measurements on this drawing are for information purposes only.

VISO © 2018 All rights reserved.

MADE WITH ♥ IN TORONTO